

Should We Care about how Birds Fly?



Bird flight has intrigued human minds ever since the Stone Age. Paintings in Lascaux cave in France are considered the oldest representation of birds in flight made by early ancestors of humans. The ability to fly has been interpreted as a divine power by some cultures which proceeded to include wings in drawings and sculptures of their deities. In the Renaissance period, Polymaths like Leonardo Da Vinci studied birds and their motion in detail. His codex of birds mentions the objective of this study as to develop a human-powered flying machine. Even, the Wright brothers used warping wings in their flight tests mimicking the flight patterns of birds. The wing and fuselage design of fixed-wing aircraft from the earliest versions to modern jet-powered airliners is directly inspired by the bio-mechanics of large birds. However, with the success of fixed-wing aircraft, the flapping wing concepts saw declining interest as a viable design option for air vehicles. During this time, the aerodynamics of bird wings was only studied in fundamental science to answer the questions on their aerodynamic performance. However, the popularization of Unmanned Arial Vehicles (UAVs) renewed the interest in bird-inspired air vehicles with flapping wings as a possible design.

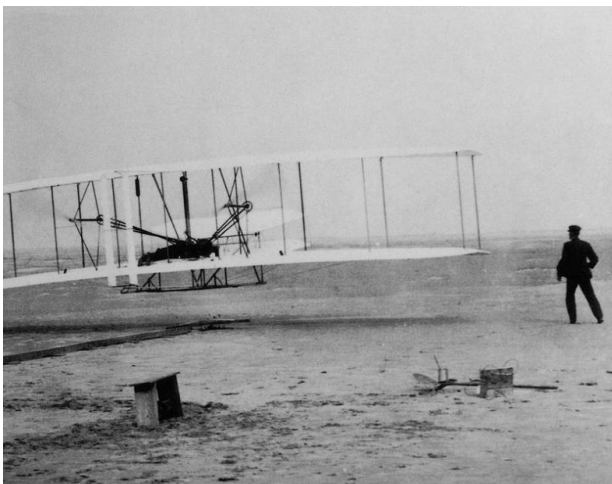

Figure 1: First flight by Wright brothers in 1903 [Source: Space Center Houston]

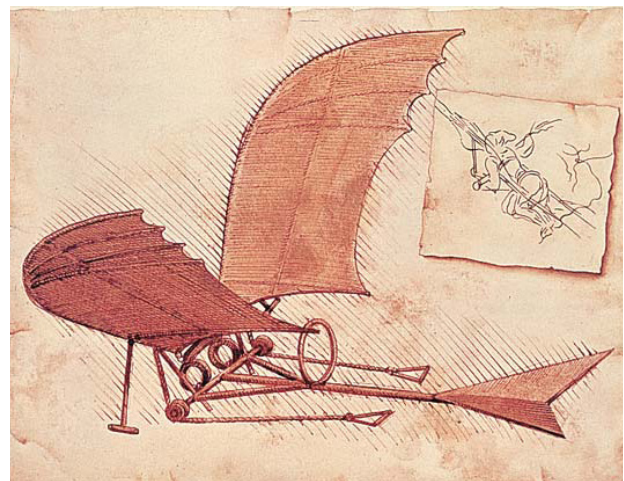

Figure 2: Flying machine (Ornithopter) by Leonardo Da Vinci [Source: leonardodavinci.net]

What is so impressive about bird flight?

Thousands of years of evolution have created optimum flight capabilities in birds. For engineers, birds are a great source of inspiration and objects of study. Migrating birds have been monitored to fly across the globe with a minimum amount of food, and the energy efficiency of such long flights has created interest in engineers in developing long-range UAVs [1].

Another area of interest is the impressive maneuverability showcased by small birds usually navigating across closely packed vegetation. Such maneuverability would allow a UAV to quick, and agile while being compact and energy efficient, a combination of qualities modern rotary wing UAVs haven't yet perfected.

How to unveil the aerodynamic secrets of birds

To unveil the secrets of bird flight, systematic and thorough investigations need to be carried out. Such investigations can be discussed in two categories. Computational investigations are performed in a virtual environment using Computational Fluid Dynamics (CFD) techniques. These CFD techniques can then be divided into numerous types based on their approaches to solving conservation equations of mass, momentum, and energy. Most popular among them is Finite Volume Method (FVM) in which the fluid dynamic volume is divided into small sections and computing the fluid flow



The Aerodynamics research group at the Department of Mechanical Engineering, University of Moratuwa is carrying out research on flapping wing flight and other bio-inspired aerodynamic phenomena. The research group consisting of professors, senior lecturers, graduate, and undergraduate researchers is developing computational and experimental methods to uncover new and exciting details about animal flight and its possible applications.

through each. Figure 3 which is a compilation of results of a FVM simulation, illustrate the variation of the wake structure during a flapping wing motion [2].

The second category is experimental investigations. Since measurements of aerodynamic forces and flow behavior can't be made in the natural environment, experimental investigations are carried out in controlled environments like wind tunnels using live birds or robotic systems. The use of robotic interpretations of flapping wings has advantages like the ease of sensor positioning and accurate repeatability of motion. The custom-developed experimental set-up consists of a wing motion control system capable of pitching and plunging motions (Figure 4) and a laser flow visualization system.

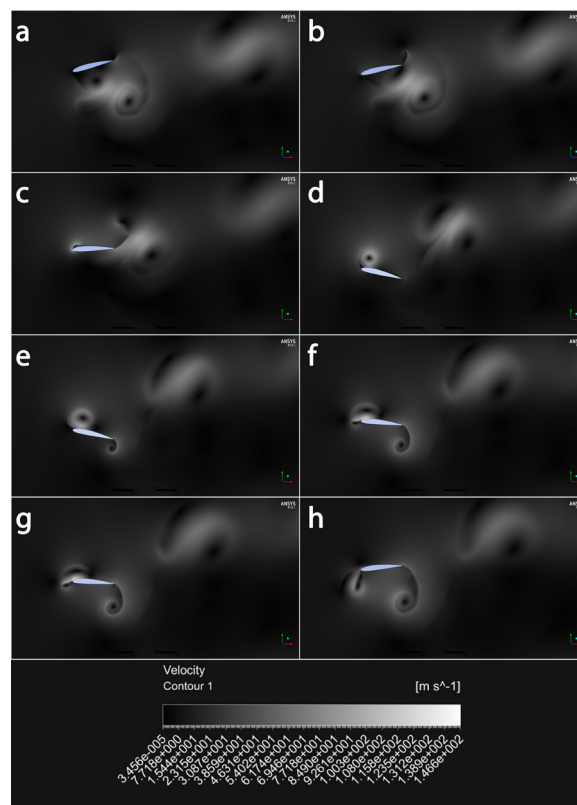

Figure 3: Velocity contours of the flow field around NACA 2412 in plunging and pitching motion at $Re = 1 \times 10^5$ and $St = 0.4$

What is the future of bird inspired aerodynamics ?

The current research and development trends on flapping wing aerodynamics are mainly focused on bio-inspired UAVs. A popular example is Festo Smartbird which have showcased the potential of innovative UAV design [3]. These advancements are most likely to yield flapping wing UAVs ready for consumers in the near future.

Furthermore, Innovative wind turbine designs that use aerodynamic forces generated by wing-wake interactions of flapping wings are being tested at laboratory levels and showcase the potential for deployment.

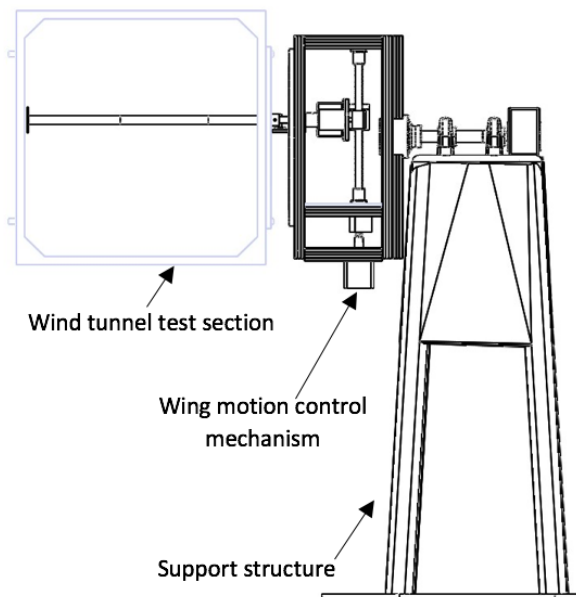

Figure 4: Wing motion control system developed for experimental investigation of pitching and plunging wings. [Source: Aeronautic Laboratory, Department of Mechanical Engineering, University of Moratuwa]

References:

- 1] L. Hedh, C. G. Guglielmo, L. C. Johansson, J. E. Deakin, C. C. Voigt, and A. Hedenström, "Measuring power input, power output and energy conversion efficiency in un-instrumented flying birds," *J. Exp. Biol.*, vol. 223, 2020, doi: 10.1242/jeb.223545.
- [2] L. De Silva, N. Samaraweera, N. Jayaweera, and T. Sugathapala, "A Computational Study of the Aerodynamics of Plunging and Pitching Motions of Airfoils," in *2022 Moratuwa Engineering Research Conference (MERCOn)*, 2022, pp. 1–6, doi: 10.1109/MERCOn55799.2022.9906181.
- [3] W. Send, M. Fischer, K. Jebens, R. Mugrauer, A. Nagarathinam, and F. Scharstein, "Artificial hinged-wing bird with active torsion and partially linear kinematics," *28th Congr. Int. Counc. Aeronaut. Sci. 2012, ICAS 2012*, vol. 2, pp. 1148–1157, 2012.

Article by:

Lakshitha De Silva, Nalaka Samaraweera, Nirosh Jayaweera, Thusitha Sugathapala
 Department of Mechanical Engineering, Faculty of Engineering,
 University of Moratuwa, Sri Lanka